

PC100

Технические характеристики

По вопросам продаж и поддержки обращайтесь:

Алматы (7273)495-231	Казань (843)206-01-48	Новокузнецк (3843)20-46-81	Смоленск (4812)29-41-54
Архангельск (8182)63-90-72	Калининград (4012)72-03-81	Новосибирск (383)227-86-73	Сочи (862)225-72-31
Астрахань (8512)99-46-04	Калуга (4842)92-23-67	Омск (3812)21-46-40	Ставрополь (8652)20-65-13
Барнаул (3852)73-04-60	Кемерово (3842)65-04-62	Орел (4862)44-53-42	Сургут (3462)77-98-35
Белгород (4722)40-23-64	Киров (8332)68-02-04	Оренбург (3532)37-68-04	Тверь (4822)63-31-35
Брянск (4832)59-03-52	Краснодар (861)203-40-90	Пенза (8412)22-31-16	Томск (3822)98-41-53
Владивосток (423)249-28-31	Красноярск (391)204-63-61	Пермь (342)205-81-47	Тула (4872)74-02-29
Волгоград (844)278-03-48	Курск (4712)77-13-04	Ростов-на-Дону (863)308-18-15	Тюмень (3452)66-21-18
Вологда (8172)26-41-59	Липецк (4742)52-20-81	Рязань (4912)46-61-64	Ульяновск (8422)24-23-59
Воронеж (473)204-51-73	Магнитогорск (3519)55-03-13	Самара (846)206-03-16	Уфа (347)229-48-12
Екатеринбург (343)384-55-89	Москва (495)268-04-70	Санкт-Петербург (812)309-46-40	Хабаровск (4212)92-98-04
Иваново (4932)77-34-06	Мурманск (8152)59-64-93	Саратов (845)249-38-78	Челябинск (351)202-03-61
Ижевск (3412)26-03-58	Набережные Челны (8552)20-53-41	Севастополь (8692)22-31-93	Череповец (8202)49-02-64
Иркутск (395)279-98-46	Нижний Новгород (831)429-08-12	Симферополь (3652)67-13-56	Ярославль (4852)69-52-93
Россия (495)268-04-70	Киргизия (996)312-96-26-47	Казахстан (7172)727-132	



PC100 Series

PC100 Series

Metal Sealed, Digital, Ultra-High Purity

Thermal Pressure Controllers & Flow Meter for Gases

Designed for semiconductor and MOCVD applications, PC100 Series pressure control and flow measurement devices deliver outstanding performance, reliability, and system simplicity. Built on the proven, advanced technology of the GF100 Series mass flow controllers, process throughput and yield are maximized while process costs are reduced.

High-purity All-metal Flow Path

The Brooks PC100 Series has an all metal, corrosion resistant Semi F20 compliant wetted flow path with highly corrosion resistant Hastelloy® C-22 valve seat and jet orifice.

- Overall reduced surface area and un-swept volumes allow for faster dry-down during purge steps
- Long-term thermal or pressure sensor and device stability maximizes yield and throughput

Advanced Thermal Flow Measurement Sensor

The PC125 with embedded flow meter includes a proprietary highly corrosion resistant Hastelloy C-22 sensor. The enhanced sensor manufacturing and burn in process incorporate a unique orthogonal sensor mounting orientation to eliminate sensor drift caused by valve heating effects and eliminate thermal siphoning effects. This unique sensor configuration includes an optimized temperature profile for gases prone to thermal decomposition. This design results in:

- Enhanced signal to noise performance for improved accuracy at low set points
- Superior reproducibility at elevated temperatures through new isothermal packaging and onboard conditioning electronics with ambient temperature sensing and compensation
- Improved long-term stability

Enhanced Diagnostics and User Interface

The Brooks PC100 Series provides for in-line device evaluation and instantaneous troubleshooting resulting in limited service interruption and reduced downtime.

- Independent diagnostic/service port
- High visibility LCD display with easy accessible push button for local indication of Flow (%), Temperature (°C), Torr/Pressure (PSIA/ kPa) and Network Address
- Zero button easily re-zeros the device during scheduled maintenance. Zero button will zero pressure transducer or the thermal sensor, depending on what is visible on the display.

Communication Interfaces

The PC100 Series supports DeviceNet™ communication protocol. DeviceNet is a multi-drop connection that allows a maximum of 64 devices to be connected on the same network. Brooks Instrument's DeviceNet profile has been certified by the ODVA™ (Open DeviceNet Vendor's Association).

PC100 Series digital pressure control with patented flow sensor combined with a high speed ARM processor and fast acting diaphragm-free valve assembly enables:

- Faster response and settling time for improved pressure control
- Reduced diverted gas consumption and associated abatement costs
- User programmable start-up function for processes requiring a slow ramped pressure control

Performance	PC115	PC125
Embedded Thermal Flow Sensor	No	Yes
Pressure Control Mode	Downstream and Upstream	Downstream
Full Scale Range	Min Flow Range: 0-20 sccm H2; 0-20 sccm N2 Max Flow Range: 0-5 slm H2; 0-5 slm N2	10 slm N2 and H2
Pressure Reading		
Reference	Downstream: 34 to 100 psia Upstream: 0 Torr to 350 Torr	34 to 100 psia
Accuracy	±1% of reading	
Zero Temp. Coefficient	±0.02% of F.S./°C	
Span Temp. Coefficient	±0.04% of reading/°C	
Pressure Control		
Range	Downstream: >20 Torr to 100% F.S. Upstream*: >150 Torr to 100% F.S.	>20 Torr to 100% F.S.
*Upstream controller turndown is directly tied to reference pressure. Control range is assuming hard vacuum on the outlet and 150 Torr min DP to achieve max flow.		
Accuracy	<10% F.S. = ±0.2% of F.S. >10% to 100% = ±1% of reading	
Response Time	<1 sec typ. (excluding system time constant)	
Flow Reading		
Measurement Range	N/A	2 to 100% of F.S.
Accuracy	N/A	±1% of reading > 35% F.S. ±0.35% of F.S. 2 to 35% F.S.
Repeatability	N/A	±0.2% of F.S.
Resolution	N/A	±0.1% of F.S.
Zero Temp. Coefficient	N/A	<0.05% of F.S./°C
Span Temp. Coefficient	N/A	<0.08% of reading/°C
Zero Stability	N/A	<0.5% per year
Valve Leak-by	<1% of orifice F.S. (N2 @ 25 psig inlet to atm.)	
Ratings		
Operating Temperature Range	10 to 50°C	
Transducer Pressure Range	1000 Torr F.S.	
Transducer Over Pressure Limit	2 x F.S. range	
Differential Pressure	Upstream min DP 150 Torr; Downstream max DP 45 psid	Max DP 45 psid
Leak Integrity (external)	1 x 10 ⁻¹⁰ atm. cc/sec He	
Electrical		
Digital Communication	DeviceNet	
Electrical Connection DeviceNet	via 5-pin "M12" connector	
Diagnostic/Service Port	RS485 via 2.5 mm jack	
Power Supply/Consumption	DeviceNet: 545 mA max. @ +11-25 Vdc	
Diagnostics & Display		
Status Lights	MFC Health, Network Status	
Display Type	Top Mount Rotatable Integrated LCD	
Viewing Distance Fixed	10 feet	
Units Displayed	Resolution Flow (%), Temp. (°C), Pressure (Torr, psia, kPa)/0.1 (unit)	
Mechanical		
Valve Type	Normally Closed	
Wetted Materials	SEMI F20 HP Compliant, 316L VIM/VAR, Hastelloy C-22, 316L Stainless Steel, 304	
Surface Finish	5µ inch Ra (0.1 µm Ra)	
Compliance		
EMC	EMC Directive 2014/30/EU CE: EN61326-1: 2013	
Environmental Compliance	RoHS Directive (2011/65/EU) REACH Directive EC 1907/2006	

Code Description	Code Option	Option Description							
I. Base Model Code	PC115	Pressure Controller, N2 & H2 at flow rates 0 to 5 slpm							
	PC125	Pressure Controller with Flow Meter, N2 & H2 at 10 SLPM only							
II. Configurability	X	Specific Gas and Range Required							
III. Flow Direction	U	Upstream (For PC115 only)							
	D	Downstream (For PC125 and PC115)							
IV. Full Scale Pressure	1000	Full Scale Pressure							
V. Pressure Measurement	T	Torr							
VI. Reference Pressure	0045	Reference Pressure - Downstream (psia) (default)							
	0004	Reference Pressure - Upstream (psia) (default)							
VII. Pressure Measurement	P	PSIA							
VIII. Gas and Flow Rate Options	0013 010L	N2 at 10 slpm (PC125)							
	0007 010L	H2 at 10 slpm (PC125)							
	XXXX XXXX	Specific Gas (H2 & N2 only), and flow rate 0 to 5 slpm for PC115							
IX. Fitting	VX	1 1/8" body width, 1/4" VCR male							
X. Communications/Connector	Option	Power On State	Full Scale Setting	Full Scale Setting	Full Scale Setting	Poll IO Instance Producer	Poll IO Instance Consumer	Poll IO State Transition	External Baud Rate
	D0	Idle	Count	Integer	6000h	2	7	Executing	500KB
	D1	Idle	Count	Integer	6000h	21	7	Executing	500KB
	D2	Idle	SCCM	Float	7FFFh	13	19	Executing	500KB
	D3	Idle	Count	Integer	6000h	22	7	Executing	500KB
	D4	Executing	Count	Integer	6000h	22	8	Executing	500KB
	D5	Idle	Count	Integer	6000h	6	8	Executing	500KB
	D6	Idle	Count	Integer	7FFFh	3	7	Executing	500KB
	D7	Idle	Count	Integer	7FFFh	6	8	Executing	500KB
	D8	Idle	Count	Integer	6000h	3	7	Executing	500KB
	D9	Executing	Count	Integer	6000h	2	7	Executing	500KB
	DA	Idle	Count	Integer	7FFFh	22	7	Executing	500KB
	DB	Idle	Count	Integer	6000h	22	8	Executing	500KB
	DC	Idle	Count	Integer	7FFFh	3	7	Idle	500KB
	DD	Executing	Count	Integer	7FFFh	22	8	Executing	500KB
	DE	Executing	SCCM	Float	6000h	15	19	Executing	500KB
	DX	To be defined by CSR							
XI. CSR	XXXX	Customer Special Request Number							
XII. Reference Temperature	000	0 Degree C Reference							
XIII. Firmware	XXX	Locked in Firmware Revision							
	LFW	Latest Firmware							
	CSR	Firmware defined by CSR							

Sample Model Code

I	II	III	IV	V	VI	VII	VIII	IX	X	XI	XII	XIII						
PC125	X	D	-	1000	T	0045	P	-	0013 010L	-	VX	DO	-	XXXX	-	000	-	108

Product Dimensions

PC100 Series - VCR® Configuration

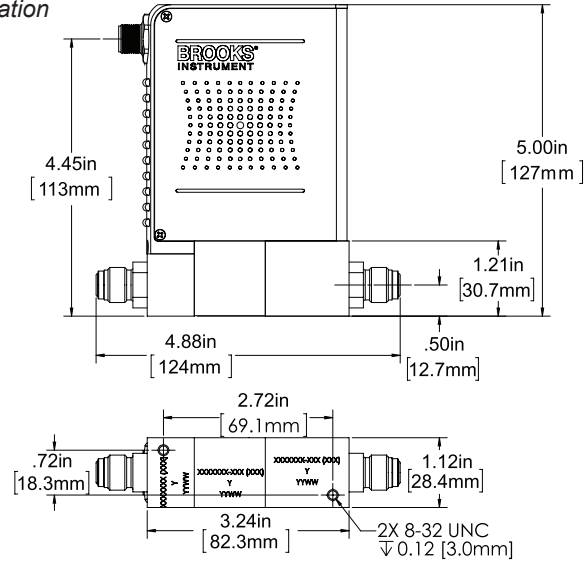

По вопросам продаж и поддержки обращайтесь:

Алматы (7273)495-231	Казань (843)206-01-48	Новокузнецк (3843)20-46-81	Смоленск (4812)29-41-54
Архангельск (8182)63-90-72	Калининград (4012)72-03-81	Новосибирск (383)227-86-73	Сочи (862)225-72-31
Астрахань (8512)99-46-04	Калуга (4842)92-23-67	Омск (3812)21-46-40	Ставрополь (8652)20-65-13
Барнаул (3852)73-04-60	Кемерово (3842)65-04-62	Орел (4862)44-53-42	Сургут (3462)77-98-35
Белгород (4722)40-23-64	Киров (8332)68-02-04	Оренбург (3532)37-68-04	Тверь (4822)63-31-35
Брянск (4832)59-03-52	Краснодар (861)203-40-90	Пенза (8412)22-31-16	Томск (3822)98-41-53
Владивосток (423)249-28-31	Красноярск (391)204-63-61	Пермь (342)205-81-47	Тула (4872)74-02-29
Волгоград (844)278-03-48	Курск (4712)77-13-04	Ростов-на-Дону (863)308-18-15	Тюмень (3452)66-21-18
Вологда (8172)26-41-59	Липецк (4742)52-20-81	Рязань (4912)46-61-64	Ульяновск (8422)24-23-59
Воронеж (473)204-51-73	Магнитогорск (3519)55-03-13	Самара (846)206-03-16	Уфа (347)229-48-12
Екатеринбург (343)384-55-89	Москва (495)268-04-70	Санкт-Петербург (812)309-46-40	Хабаровск (4212)92-98-04
Иваново (4932)77-34-06	Мурманск (8152)59-64-93	Саратов (845)249-38-78	Челябинск (351)202-03-61
Ижевск (3412)26-03-58	Набережные Челны (8552)20-53-41	Севастополь (8692)22-31-93	Череповец (8202)49-02-64
Иркутск (395)279-98-46	Нижний Новгород (831)429-08-12	Симферополь (3652)67-13-56	Ярославль (4852)69-52-93
Россия (495)268-04-70	Киргизия (996)312-96-26-47	Казахстан (7172)727-132	