

GF100 EtherCAT

Технические характеристики

По вопросам продаж и поддержки обращайтесь:

Алматы (7273)495-231
Архангельск (8182)63-90-72
Астрахань (8512)99-46-04
Барнаул (3852)73-04-60
Белгород (4722)40-23-64
Брянск (4832)59-03-52
Владивосток (423)249-28-31
Волгоград (844)278-03-48
Вологда (8172)26-41-59
Воронеж (473)204-51-73
Екатеринбург (343)384-55-89
Иваново (4932)77-34-06
Ижевск (3412)26-03-58
Иркутск (395)279-98-46
Россия (495)268-04-70

Казань (843)206-01-48
Калининград (4012)72-03-81
Калуга (4842)92-23-67
Кемерово (3842)65-04-62
Киров (8332)68-02-04
Краснодар (861)203-40-90
Красноярск (391)204-63-61
Курск (4712)77-13-04
Липецк (4742)52-20-81
Магнитогорск (3519)55-03-13
Москва (495)268-04-70
Мурманск (8152)59-64-93
Набережные Челны (8552)20-53-41
Нижний Новгород (831)429-08-12
Киргизия (996)312-96-26-47

Новокузнецк (3843)20-46-81
Новосибирск (383)227-86-73
Омск (3812)21-46-40
Орел (4862)44-53-42
Оренбург (3532)37-68-04
Пенза (8412)22-31-16
Пермь (342)205-81-47
Ростов-на-Дону (863)308-18-15
Рязань (4912)46-61-64
Самара (846)206-03-16
Санкт-Петербург (812)309-46-40
Саратов (845)249-38-78
Севастополь (8692)22-31-93
Симферополь (3652)67-13-56
Казахстан (7172)727-132

Смоленск (4812)29-41-54
Сочи (862)225-72-31
Ставрополь (8652)20-65-13
Сургут (3462)77-98-35
Тверь (4822)63-31-35
Томск (3822)98-41-53
Тула (4872)74-02-29
Тюмень (3452)66-21-18
Ульяновск (8422)24-23-59
Уфа (347)229-48-12
Хабаровск (4212)92-98-04
Челябинск (351)202-03-61
Череповец (8202)49-02-64
Ярославль (4852)69-52-93

GF100 Series with EtherCAT®

The Fastest and Most Accurate MFCs
Enhanced with the Speed of EtherCAT®



GF100 Series
with EtherCAT®

High Purity/Ultra-High Purity Thermal Mass Flow Controllers and Meters

Through hundreds of thousands of installations, the GF100 Series has been proven to have the fastest response time and most accurate performance of any mass flow controller on the market today, enabling precision gas chemistry control. Now enhanced with the speed of EtherCAT® (an Ethernet based communication system known for its cost efficient cabling and application efficiency), the GF100 Series delivers improved key specifications for the increasing demands of semiconductor processes.

Features & Benefits

- All-metal seal flow path: option for 5 μ or 10 μ inch Ra surface finish
- Real-time EtherCAT® data acquisition capabilities
- Improved valve shutdown ($\leq 0.15\%$ of bin range) reduces valve leak-by to reduce first wafer effects
- Ultra-stable flow sensor ($\leq 0.15\%$ of F.S. drift per year) enables tighter low set point accuracy and reduces maintenance requirements ensuring long term zero stability
- Newly enhanced pressure transient insensitivity reduces crosstalk sensitivity for consistent mass flow delivery
- Ultra-fast settling times: as low as 300 ms
- MultiFlo™ technology enables one MFC to support thousands of gas types and range combinations without removing it from the gas line or compromising on accuracy
- GF120 Safe Delivery System (SDS®) low pressure drop MFC for the delivery of sub atmospheric safe delivery system (SDS) gases used in Implant and Etch processes

Product Specifications

Performance ¹	GF100	GF120	GF125	GF120XSL	GF120XSD
Full Scale Flow Range	3 sccm to 55 slm			4 sccm to 25 sccm	>25 sccm to 1 slpm
Flow Accuracy	±1% S.P. > 20-100%; ±0.2% F.S. 2-20%			±1% S.P. 35-100%; ±0.35% F.S. 2-35%	
Repeatability & Reproducibility	5-100% = ± 0.15% of S.P. 2-5% = ± 0.015% of F.S.				
Flow Settling Time (NC Valve)	< 1 sec	700ms	300ms (3-860 sccm) 400ms (861-7200 sccm) 500ms (7201-30000 sccm) <700ms (30001-55000 sccm)	< 3 sec	
Flow Settling Time (N.O. Valve)	<1.5 sec			-----	
Pressure Insensitivity	Not Applicable		< 1% S.P. up to 5 psi/sec upstream press. spike	-----	
Control Range	2-100% (Normally Closed Valve) 3-100% (Normally Open Valve)			2-100% (Normally Closed Valve)	
MultiFlo	Standard			-----	
#of Bins	11 bins			-----	
Valve Shut Down (N.C. Valve) ²	Standard Hastelloy Valve: <0.15% of F.S. Zero Leak Valve: SH40 – SH41 <0.02% of F.S. SH42 – SH50 <0.005% of F.S.			Standard Hastelloy Valve: <0.15% of F.S.	
Valve Shut Down (N.O. Valve)	2% of F.S.			-----	
Zero Stability	< ± 0.15% F.S. per year			< ± 0.6% F.S. per year	
Temperature Coefficient	Zero: 0.005% F.S. per °C; Span: 0.05% F.S. per °C				

Ratings

Operating Temperature Range	10-50°C				
Differential Pressure Range ³	3-860 sccm = 7-45 psid 861- 7200 sccm = 10-45 psid 7201-55000 sccm = 15-45 psid			10 Torr - 30 psid typical For more details consult factory	
Proof Pressure	700 psia max		140 psia max	700 psia max	
Design Pressure	800 psia max		170 psia max	800 psia max	
Burst Pressure	3000 psia max		500 psia max	3000 psia max	
Maximum Operating Pressure	500 psia max		100 psia max	up to 500 psia max	
Leak Integrity (external)	1x10 ⁻¹⁰ atm. cc/sec He				

Mechanical

Valve Type	Normally Closed (Standard or Zero Leak-by) Normally Open Meter (no valve)			Normally Closed	
Wetted Materials	SEMI F20 HP Compliant, 316L VIM/VAR, Hastelloy C-22, 316L Stainless Steel, 304 Stainless Steel, KM-45, PCTFE (on optional Zero leak Valve)				
Surface Finish	10µ inch Ra	5µ inch Ra		5µ inch Ra	

Diagnostics & Display

Status Lights	Run, Error, Power, Network Status				
Alarms	Control Valve Output, Network Interruption, Temperature High/Low, Pressure High/Low, Power Surge/Sag				
Display Type	Top Mount Integrated LCD				
Viewing Angle/Viewing Distance	Rotatable / 10 feet				
Units Displayed/Resolution	Flow (%), Temp. (°C), Pressure (psia, kPa) / 0.1 (unit)				

¹ Based on factory N₂ calibration

² The Zero Leak Valve can be ordered via Brooks CSR process

³ Argon gas applications require an additional 10 psid differential pressure.

Low vapor pressure gases require an inlet pressure of > 100 Torr, with vacuum on outlet (example SiCl₄). Contact Brooks Technical Support for more information.

Performance	GF100	GF120	GF125	GF120XSL	GF120XSD
Electrical					
Electrical Connection	Power via 5-pin M8 Connector, EtherCAT via RJ45 jacks				
Digital Communication	EtherCAT				
Diagnostic /Service Port	Micro-USB				
Power Supply/Consumption	320 mA max. @ 18-30 Vdc, 230 mA max. @ 24 Vdc (under typical operating conditions)				
Compliance					
EMC	EMC Directive 2014/30/EU Evaluation Standard EN61326-1:2013				
Environmental Compliance	RoHS Directive (2011/65/EU) REACH Directive EC (1907/2006)				

Performance ¹	GF101	GF121	GF126
Full Scale Flow Range	55 slm to 300 slm		
Flow Accuracy	±1% S.P. > 35-100%; ±0.35% F.S. 2-35%		
Repeatability & Reproducibility	< ± 0.15% S.P		
Response Time/Settling Time (N.C. Valve)	< 1 sec		
Pressure Insensitivity	Not Applicable		Ability to measure inlet pressure
Control Range	5-100% (Normally Closed Valve)		
MultiFlo	Standard		
#of Bins	4 bins		
Valve Shut Down (N.C. Valve)	<2% of F.S. @30 N ₂ psig/atm out		
Zero Stability	< ± 0.15% F.S. per year		
Temperature Coefficient	Zero: 0.005% F.S. per °C; Span: 0.05% F.S. per °C		

Ratings

Operating Temperature Range	10-50°C		
Differential Pressure Range	30-90 psid		
Maximum Operating Pressure	Controller: 75 psig Meter: 150 psig		
Proof Pressure	700 psia	700 psia	140 psia
Design Pressure	800 psia	800 psia	170 psia
Burst Pressure	3000 psia	3000 psia	500 psia
Leak Integrity (external)	1x10 ⁻¹⁰ atm. cc/sec He		

Mechanical

Valve Type	Normally Closed Meter (no valve)		
Wetted Materials	SEMI F20 HP Compliant, 316L VIM/VAR, Hastelloy C-22, 316L Stainless Steel, 304 Stainless Steel, KM-45		
Surface Finish	10µ inch Ra	5µ inch Ra	

Dignostics & Display

Status Lights	Run, Error, Power, Network Status		
Alarms	Control Valve Output, Network Interruption, Temperature High/Low, Pressure High/Low, Power Surge/Sag		
Display Type	Top Mount Integrated LCD		
Viewing Angle / Viewing Distance	Rotatable / 10 feet		
Units Displayed / Resolution	Flow (%), Temp. (°C), Pressure (psia, kPa) / 0.1 (unit)		

Electrical

Electrical Connection	Power via 5-pin M8 Connector, EtherCAT via RJ45 jacks		
Digital Communication	EtherCAT		
Diagnostic /Service Port	Micro-USB		
Power Supply/Consumption	320 mA max. @ 18-30 Vdc, 230 mA max. @ 24 Vdc (under typical operating conditions)		

Compliance

EMC	Environmental Compliance		
Environmental Compliance	RoHS Directive (2011/65/EU) REACH Directive EC (1907/2006)		

¹ Based on factory N₂ calibration

Product Dimensions - Surface Mount Configurations

GF100/120/125

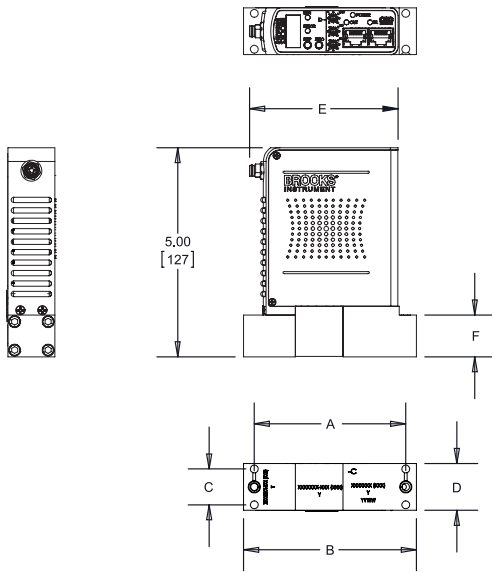

GF101/121/126

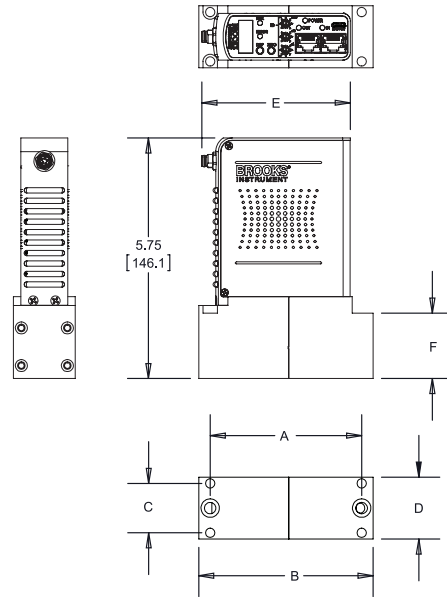

Fitting Option Code	Model	Seal Type	Dim A	Dim b	Dim C	Dim D	Dim E	Dim F
CX	GF100/120/ 125	C-Seal	3.62 [92]	4.13 [105]	0.86 [21.7]	1.12 [28.4]	3.55 [90.2]	1.00 [25.4]
WX	GF100/120/ 125	W-Seal	3.62 [92]	4.13 [105]	0.86 [21.7]	1.12 [28.4]	3.55 [90.2]	1.00 [25.4]
C1	GF101/121/126	C-Seal	3.62 [92]	4.17 [106]	1.18 [30]	1.48 [37.6]	3.55 [90.2]	1.57 [39.8]
C2	GF101/121/126	C-Seal	4.49 [114]	5.00 [127]	1.18 [30]	1.48 [37.6]	3.55 [90.2]	1.57 [39.8]

NOTE: [] ALTERNATE DIMENSION UNITS ARE FOR REFERENCE ONLY.

GF100/120/125

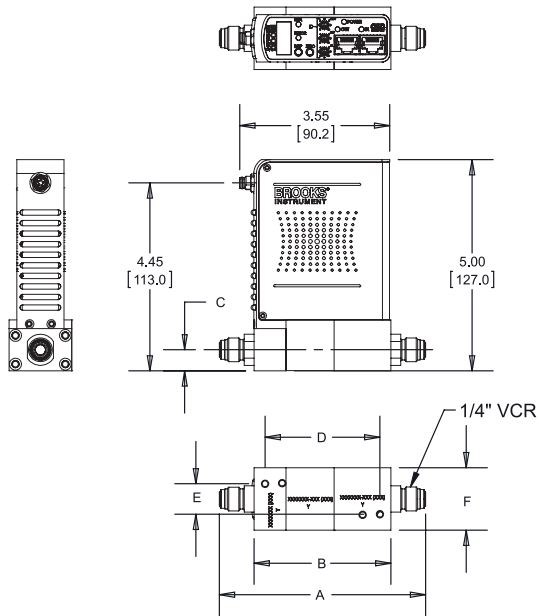

GF101/121/126

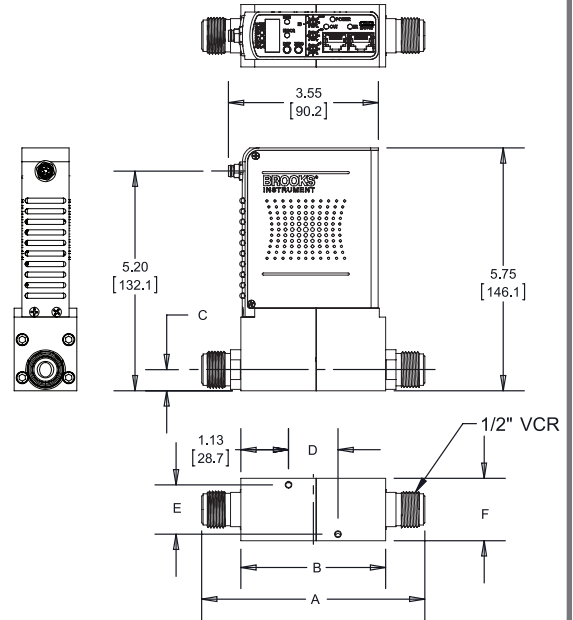

Fitting Option Code	Model	VCR	Dim A	Dim B	Dim C	Dim D	Dim E	Dim F
VS	GF100/120/ 125	1/4 "	4.88 [124]	3.24 [82]	0.50 [12.7]	2.72 [69]	0.72 [18]	1.12 [28.4]
VX	GF100/120/ 125	1/4 "	4.88 [124]	3.24 [82]	0.50 [12.7]	2.72 [69]	0.72 [18]	1.48 [37.6]
V1	GF101/121/ 126	1/2 "	5.28 [134.2]	3.43 [87]	0.50 [12.7]	1.17 [29.7]	1.17 [29.7]	1.48 [37.6]

NOTE: [] ALTERNATE DIMENSION UNITS ARE FOR REFERENCE ONLY.

Code Description	Code Option	Option Description
I. Base Model Code	GF	High Purity/Ultra High Purity Digital Mass Flow Controllers
II. Package / Finish Specifications	100	Flow range 3 sccm - 55 slpm N2 Equivalent.; 1 sec Response; 10 Ra
	120	Flow range 3 sccm - 55 slpm N2 Equivalent.; 700 msec Response; 5 Ra
	125	Pressure Transient Insensitive (PTI) Flow range 3 sccm -55 slpm N2 Equivalent; 300-700 msec Response; 5 Ra
III. Configurability	C	MultiFlo capable. Standard bins or specific gas/range may be selected.
	X	Not MultiFlo capable. Specific gas/range required. (must select w/ SD or SL special application)
IV. Special Application	XX	Standard
	SL	Safe Delivery System (GF120 Only) Full scale flow range; 4 to 25 sccm, N2 Equivalent
	SD	Safe Delivery System (GF120 Only) Full scale flow range; 25 sccm to 1 slpm, N2 Equivalent
V. Valve Configuration	O	Normally Open valve (not available with SD, SL or VS options)
	C	Normally Closed valve
	M	Meter (No Valve)
VI. Gas or SH MultiFlo Bin	XXXX XXXX	Specific Gas Code & Range, i.e. "0004" = Argon and "010L" = 10 slpm
	SH40 010C	Standard Configuration #40, 3-10 sccm Nitrogen Equivalent
	SH41 030C	Standard Configuration #41, 11-30 sccm Nitrogen Equivalent
	SH42 092C	Standard Configuration #42, 31-92 sccm Nitrogen Equivalent
	SH43 280C	Standard Configuration #43, 93-280 sccm Nitrogen Equivalent
	SH44 860C	Standard Configuration #44, 281-860 sccm Nitrogen Equivalent
	SH45 2.6L	Standard Configuration #45, 861-2600 sccm Nitrogen Equivalent
	SH46 7.2L	Standard Configuration #46, 2601-7200 sccm Nitrogen Equivalent
	SH47 015L	Standard Configuration #47, 7201-15000 sccm Nitrogen Equivalent
	SH48 030L	Standard Configuration #48, 15001-30000 sccm Nitrogen Equivalent
	SH49 040L	Standard Configuration #49, 30001-40000 sccm Nitrogen Equivalent
	SH50 055L	Standard Configuration #50, 40001-55000 sccm Nitrogen Equivalent
VII. Fitting	VS	1-1/8" body width, 1/4" VCR male
	VX	1-1/2" body width, 1/4" VCR male
	CX	1-1/8" body width, C Seal 92mm
	WX	1-1/8" body width, W Seal 92mm
VIII. Downstream Condition	A	Atmosphere
	V	Vacuum
IX. Sensor	O	Default Sensor Orientation
X. Connector	E0	EtherCAT Communication
XI. Customer Special Request	XXXX	Customer Special Request Number
XII. Auto Shut-Off	A	Auto Shut-Off (Included)
	X	Auto Shut-Off (Not Included)
XIII. Auto Zero	X	Auto Zero (Not Included)
XIV. Reference Temperature	000	0 deg C Reference Calibration (Standard) - Default Setting

Code Description	Code Option	Option Description
I. Base Model Code	GF	High Purity/Ultra High Purity Digital Mass Flow Controllers
II. Package / Finish Specifications	101	Flow range 55 - 300 slm N2 Equivalent.; 10 Ra HP wetted flow path
	121	Flow range 55 - 300 slm N2 Equivalent 5 Ra HP wetted flow path
	126	Flow range 55 - 300 slm N2 Equivalent 5 Ra HP wetted flow path & integrated pressure measurement
III. Configurability	C	MultiFlo capable. Standard bins or specific gas/range may be selected
	X	Not MultiFlo capable. Specific gas/range required
IV. Special Application	XX	Standard
V. Valve Configuration	C	Normally Closed valve
	M	Meter (No Valve)
VI. Gas or SH MultiFlo Bin	XXXX XXXX	Specific Gas Code & Range, i.e. "0004" = Argon and "010L" = 10 slpm
	SH51 055L	Standard Configuration #51, 55,001 sccm N2 Equivalent (0°C Reference)
	SH52 100L	Standard Configuration #52, 55,002-100,000 sccm N2 Equivalent (0°C Reference)
	SH53 200L	Standard Configuration #53, 100,001-200,000 sccm N2 Equivalent (0°C Reference)
	SH54 300L	Standard Configuration #54, 200,001-300,000 N2 Equivalent (0°C Reference)
VII. Fitting	V1	1-1/2" body width, 134mm 1/2" VCR male
	C1	1-1/2" body width, 92mm 3/8" C Seal
	C2	1-1/2" body width, 114mm C Seal
VIII. Downstream Condition	A	Atmosphere
	V	Vacuum
IX. Sensor	O	Default Sensor Orientation
X. Connector	E0	EtherCAT Communication
XI. Customer Special Request	XXXX	Customer Special Request (CSR) Number
XII. Auto Shut-Off	A	Auto Shut-Off (Included)
	X	Auto Shut-Off (Not Included)
XIII. Auto Zero	X	Auto Zero (Not Included)
XIV. Reference Temperature	000	0°C Reference Calibration (Standard) - Default Setting

По вопросам продаж и поддержки обращайтесь:

Алматы (7273)495-231	Казань (843)206-01-48	Новокузнецк (3843)20-46-81	Смоленск (4812)29-41-54
Архангельск (8182)63-90-72	Калининград (4012)72-03-81	Новосибирск (383)227-86-73	Сочи (862)225-72-31
Астрахань (8512)99-46-04	Калуга (4842)92-23-67	Омск (3812)21-46-40	Ставрополь (8652)20-65-13
Барнаул (3852)73-04-60	Кемерово (3842)65-04-62	Орел (4862)44-53-42	Сургут (3462)77-98-35
Белгород (4722)40-23-64	Киров (8332)68-02-04	Оренбург (3532)37-68-04	Тверь (4822)63-31-35
Брянск (4832)59-03-52	Краснодар (861)203-40-90	Пенза (8412)22-31-16	Томск (3822)98-41-53
Владивосток (423)249-28-31	Красноярск (391)204-63-61	Пермь (342)205-81-47	Тула (4872)74-02-29
Волгоград (844)278-03-48	Курск (4712)77-13-04	Ростов-на-Дону (863)308-18-15	Тюмень (3452)66-21-18
Вологда (8172)26-41-59	Липецк (4742)52-20-81	Рязань (4912)46-61-64	Ульяновск (8422)24-23-59
Воронеж (473)204-51-73	Магнитогорск (3519)55-03-13	Самара (846)206-03-16	Уфа (347)229-48-12
Екатеринбург (343)384-55-89	Москва (495)268-04-70	Санкт-Петербург (812)309-46-40	Хабаровск (4212)92-98-04
Иваново (4932)77-34-06	Мурманск (8152)59-64-93	Саратов (845)249-38-78	Челябинск (351)202-03-61
Ижевск (3412)26-03-58	Набережные Челны (8552)20-53-41	Севастополь (8692)22-31-93	Череповец (8202)49-02-64
Иркутск (395)279-98-46	Нижний Новгород (831)429-08-12	Симферополь (3652)67-13-56	Ярославль (4852)69-52-93
Россия (495)268-04-70	Киргизия (996)312-96-26-47	Казахстан (7172)727-132	