

# 8503F/8504F

## Технические характеристики

### По вопросам продаж и поддержки обращайтесь:

Алматы (7273)495-231	Казань (843)206-01-48	Новокузнецк (3843)20-46-81	Смоленск (4812)29-41-54
Архангельск (8182)63-90-72	Калининград (4012)72-03-81	Новосибирск (383)227-86-73	Сочи (862)225-72-31
Астрахань (8512)99-46-04	Калуга (4842)92-23-67	Омск (3812)21-46-40	Ставрополь (8652)20-65-13
Барнаул (3852)73-04-60	Кемерово (3842)65-04-62	Орел (4862)44-53-42	Сургут (3462)77-98-35
Белгород (4722)40-23-64	Киров (8332)68-02-04	Оренбург (3532)37-68-04	Тверь (4822)63-31-35
Брянск (4832)59-03-52	Краснодар (861)203-40-90	Пенза (8412)22-31-16	Томск (3822)98-41-53
Владивосток (423)249-28-31	Красноярск (391)204-63-61	Пермь (342)205-81-47	Тула (4872)74-02-29
Волгоград (844)278-03-48	Курск (4712)77-13-04	Ростов-на-Дону (863)308-18-15	Тюмень (3452)66-21-18
Вологда (8172)26-41-59	Липецк (4742)52-20-81	Рязань (4912)46-61-64	Ульяновск (8422)24-23-59
Воронеж (473)204-51-73	Магнитогорск (3519)55-03-13	Самара (846)206-03-16	Уфа (347)229-48-12
Екатеринбург (343)384-55-89	Москва (495)268-04-70	Санкт-Петербург (812)309-46-40	Хабаровск (4212)92-98-04
Иваново (4932)77-34-06	Мурманск (8152)59-64-93	Саратов (845)249-38-78	Челябинск (351)202-03-61
Ижевск (3412)26-03-58	Набережные Челны (8552)20-53-41	Севастополь (8692)22-31-93	Череповец (8202)49-02-64
Иркутск (395)279-98-46	Нижний Новгород (831)429-08-12	Симферополь (3652)67-13-56	Ярославль (4852)69-52-93
Россия (495)268-04-70	Киргизия (996)312-96-26-47	Казахстан (7172)727-132	

# Needle Control Valves Models 8503 and 8504

Variable Area



Model 8504  
Straight Pattern  
CART III Needle Valve

Model 8503  
Angle 90° Pattern  
CART III Needle Valve

## Low Flow Gas and Liquid Flow Control Valves

### Description

Model 8503 (angle, or 90° pattern) and Model 8504 (straight, or “in-line” pattern) needle control valves incorporate either the Brooks Cartridge III series of standard resolution, or the Brooks NRS™ series of precision resolution control valves. Both of these Brooks valve series are combined with cast 316 stainless steel bodies to provide a full range of control for low flow gas and liquid applications.

The Brooks Cartridge III (“CART III”) valve is a multi-purpose valve, designed for integral use in the Brooks Sho-Rate™ 1350G/1355G series of “Purgemeters”, as well as for use as a stand-alone needle valve, when incorporated in the 8503/8504 bodies. These valves are available in three different sizes - Low, Medium and High. The needle valve stem of this design features a conical taper, which, when combined with various ceramic orifices, ensures a wide range of flow capacities for common gas and liquid purge-type applications.

The Brooks NRS™ (non-rising stem) valve is designed specifically for extremely low flow gas and liquid applications. These valves feature a unique means of precisely adjusting an orifice along a tapered needle, and are particularly suited for critical flow control requirements. Due to its non-rising stem design, this valve is significantly less susceptible to changes in ambient temperature and mechanical effects than a conventional needle control valve.

### Features

#### CART III

- Large, easy to set knob
- Rugged design, with stable flow adjustment and repeatability
- Eight turns open-to-close
- Wide flow rangeability provided by three, overlapping valve sizes

#### NRS™

- Smooth, non-reversing flow characteristics
- Constant flow at any given knob position
- Excellent resolution with fifteen turns open-to-close
- Seven needle tapers (Sizes 1-7) provide overlapping ranges, each size increasing maximum capacity by approximately three times
- O-ring seal design provides tight shut-off, and incorporates a mechanical stop to eliminate overtightening damage
- Panel mounting nuts are standard

#### Common

- 1/8” FNPT integral connections or 1/4” FNPT connections via included adapters

## Product Specifications

Capacities and Pressure Drops	See Capacity Table
Max. Operating Pressure	1000 psig
Max. Operating Temperature	250°F
Connections	Standard: 1/8" Female NPT - integral 1/4" female NPT
Dimensions	See Dimensions Figure
<b>Materials of Construction Stainless Steel Model</b>	
Body & Stem	316 stainless steel
Orifice	NRS Size 1-3: Stainless steel and Teflon®; NRS Sizes 4-6: Stainless Steel; CART III all sizes: PEEK® (ceramic)
Valve Needle	316 stainless steel
Plunger (NRS only)	Stainless steel
O-rings	Viton® fluoroelastomers; Buna-N

### Capacity Table

NRS								
Needle Taper	Air	He	Water	Cv	Kv			
Units	SLPM* (N)M3/HR**	SLPM (N)M3/HR	LPM L/HR					
1	0.15	0.01	0.3	0.02	0.004	0.292	0.0003	0.00031
2	0.35	0.02	0.7	0.04	0.01	0.73	0.0007	0.00073
3	0.6	0.04	1.4	0.08	0.02	1.46	0.0013	0.00126
4	2.4	0.14	6	0.36	0.08	5.84	0.0057	0.00502
5	6.8	0.41	18	1.07	0.2	14.6	0.017	0.01423
6	22	1.31	55	3.28	0.65	47.45	0.052	0.04602
7	43.8	2.61	109.5	6.53	1.35	98.55	0.112	0.09163
CART III Size								
Low	5.7	0.34	14.9	0.89	0.176	13	0.015	0.012
Medium	19.7	1.17	50	2.98	0.712	51	0.05	0.044
High	75.6	4.51	94	5.60	2.04	147	0.193	0.167

\*U.S. Customary Units capacities measured with 10 PSIG supply and atmospheric exhaust. Standard Temperature is 70°F and Standard Pressure is 14.7 PSIA.  
 \*\*Standard International (SI) Units measured with 1 BarG supply and atmospheric exhaust. Normal Temperature is 21.1°C and Normal Pressure is 1.013 Bar.  
 Flow capacities will vary for different gases, liquids and valve pressure drop (ΔP).

## Product Dimensions

### Model 8503F

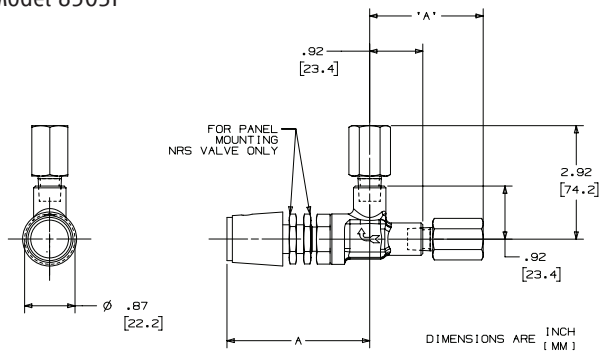

#### NOTES:

1. VALVE BODY IS 1/8"NPT INTEGRAL CONNECTION, NO ADAPTER NEEDED.

	A (OPEN)
NRS VALVE	2.50 [63.5]
CARTRIDGE III VALVE	2.65 [67.3]

### Model 8504F

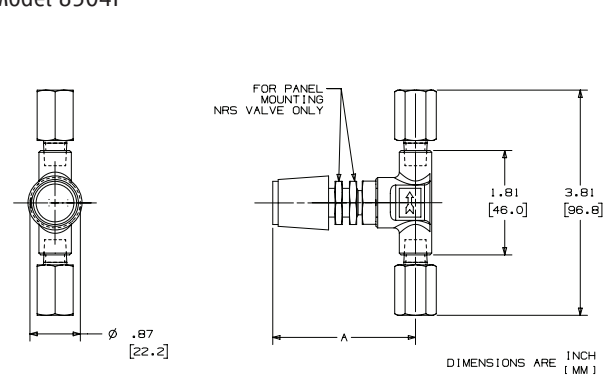

#### NOTES:

1. VALVE BODY IS 1/8"NPT INTEGRAL CONNECTION, NO ADAPTER NEEDED.

	A (OPEN)
NRS VALVE	2.50 [63.5]
CARTRIDGE III VALVE	2.65 [67.3]

## Cartidge Valve Sizing

### GAS - United States Customary Units

The correct cartridge valve can be determined for any gas by using one of the formulas below:

1. Subcritical Flow Formula (when downstream pressure,  $P_2$ , is greater than the critical pressure  $P_c$ , or  $P_1 < 2P_2$ )

$$C_v = \frac{Q}{454} \sqrt{\frac{(SG) \times (T)}{P_1^2 - P_2^2}}$$

2. Critical Flow Formula (when downstream pressure,  $P_2$ , is less than the critical pressure  $P_c$ , or  $P_1 > 2P_2$ )

$$C_v = \frac{Q \sqrt{(SG) \times (T)}}{385 \times P_1}$$

Note: Critical pressure is equal to approximately 1/2 of the upstream absolute pressure. ( $P_c = 1/2 P_1$ )

Where:

- $C_v$  = Valve flow coefficient
- $Q$  = Gas flow in slpm
- $SG$  = Gas specific gravity (See Specific Gravity Table)
- $T$  = Absolute temp. of flowing gas in °R (°F + 460)
- $P_1$  = Upstream pressure (psia)
- $P_2$  = Downstream pressure (psia)
- $P_c$  = Critical pressure (psia)

### LIQUID - United States Customary Units

The correct needle valve can be determined for any liquid by using the formula below:

$$C_v = 0.264 (Q) \sqrt{\frac{(SG)}{\Delta P}}$$

Where:

- $C_v$  = Valve flow coefficient
- $Q$  = Liquid flow (slpm)
- $\Delta P$  = Pressure drop (psi)
- $SG$  = Liquid specific gravity

### Specific Gravity and Density Table for Gases

Gas	Specific Gravity Referred to Air at 70°F (SG)	Density (kg/m <sup>3</sup> )
Acetylene	0.907	1.173
Air	1.0	1.293
Ammonia	0.587	0.771
Argon	1.38	1.784
Butane	2.07	2.593
Carbon Dioxide	1.529	1.977
Helium	0.138	0.178
Hydrogen	0.0695	0.090
Methane	0.554	0.717
Nitrogen	0.967	1.251
Oxygen	1.105	1.429
Propane	1.562	2.008
Sulfur Dioxide	2.264	2.858

### GAS - Standard International Units

The correct cartridge valve can be determined for any gas by using one of the formulas below:

1. Subcritical Flow Formula (when downstream pressure,  $P_2$ , is greater than the critical pressure  $P_c$ , or  $P_1 < 2P_2$ )

$$K_v = \frac{Q_{max}}{514} \sqrt{\frac{\text{density}(T)}{\Delta P (P_2)}}$$

2. Critical Flow Formula (when downstream pressure,  $P_2$ , is less than the critical pressure  $P_c$ , or  $P_1 > 2P_2$ )

$$K_v = \frac{Q_{max}}{257(P_1)} \sqrt{\text{density}(T)}$$

Where:

- $K_v$  = Valve flow coefficient
- $Q_{max}$  = Gas flow (m<sup>3</sup>/h)
- Density = Gas density (kg/m<sup>3</sup>) (See Specific Gravity Table)
- $T$  = Absolute actual operating temp. °K (°C + 273)
- $P_1$  = Upstream pressure (bar abs)
- $P_2$  = Downstream pressure (bar abs)
- $\Delta P$  = Pressure drop (bar)

### LIQUID - Standard International Units

The correct cartridge valve can be determined for any liquid by using the formula below:

$$K_v = (Q_{max}) \sqrt{\frac{\text{density}}{\Delta P(1000)}}$$

Where:

- $K_v$  = Valve flow coefficient
- $Q_{max}$  = Liquid flow (m<sup>3</sup>/h)
- $D$  = Fluid density (kg/m<sup>3</sup>)
- $\Delta P$  = Pressure drop (bar)

## Model Code

Code Description	Code Option	Option Description
I. Base Model Number	8503F	Angle pattern
	8504F	In-line pattern
II. Material of Construction	2	316 Stainless Steel
III. Needle and Orifice Size	A	NRS Size 1
	B	NRS Size 2
	C	NRS Size 3
	D	NRS Size 4
	E	NRS Size 5
	F	NRS Size 6
	G	NRS Size 7
	1	CART III Low
	2	CART III Medium
	3	CART III High
IV. O-ring Material	A	Buna N
	B	Viton® fluoroelastomers
V. Inlet/Outlet Connections, Size & Type	1A	1/8" NPT (integral)
	3C	1/4" NPT (adapters supplied)

### Sample Standard Model Code

I	II	III	IV	V
8504F	2	1	B	1A

**По вопросам продаж и поддержки обращайтесь:**

Алматы (7273)495-231	Казань (843)206-01-48	Новокузнецк (3843)20-46-81	Смоленск (4812)29-41-54
Архангельск (8182)63-90-72	Калининград (4012)72-03-81	Новосибирск (383)227-86-73	Сочи (862)225-72-31
Астрахань (8512)99-46-04	Калуга (4842)92-23-67	Омск (3812)21-46-40	Ставрополь (8652)20-65-13
Барнаул (3852)73-04-60	Кемерово (3842)65-04-62	Орел (4862)44-53-42	Сургут (3462)77-98-35
Белгород (4722)40-23-64	Киров (8332)68-02-04	Оренбург (3532)37-68-04	Тверь (4822)63-31-35
Брянск (4832)59-03-52	Краснодар (861)203-40-90	Пенза (8412)22-31-16	Томск (3822)98-41-53
Владивосток (423)249-28-31	Красноярск (391)204-63-61	Пермь (342)205-81-47	Тула (4872)74-02-29
Волгоград (844)278-03-48	Курск (4712)77-13-04	Ростов-на-Дону (863)308-18-15	Тюмень (3452)66-21-18
Вологда (8172)26-41-59	Липецк (4742)52-20-81	Рязань (4912)46-61-64	Ульяновск (8422)24-23-59
Воронеж (473)204-51-73	Магнитогорск (3519)55-03-13	Самара (846)206-03-16	Уфа (347)229-48-12
Екатеринбург (343)384-55-89	Москва (495)268-04-70	Санкт-Петербург (812)309-46-40	Хабаровск (4212)92-98-04
Иваново (4932)77-34-06	Мурманск (8152)59-64-93	Саратов (845)249-38-78	Челябинск (351)202-03-61
Ижевск (3412)26-03-58	Набережные Челны (8552)20-53-41	Севастополь (8692)22-31-93	Череповец (8202)49-02-64
Иркутск (395)279-98-46	Нижний Новгород (831)429-08-12	Симферополь (3652)67-13-56	Ярославль (4852)69-52-93
Россия (495)268-04-70	Киргизия (996)312-96-26-47	Казахстан (7172)727-132	