

GT1600

Технические характеристики

По вопросам продаж и поддержки обращайтесь:

Алматы (7273)495-231	Казань (843)206-01-48	Новокузнецк (3843)20-46-81	Смоленск (4812)29-41-54
Архангельск (8182)63-90-72	Калининград (4012)72-03-81	Новосибирск (383)227-86-73	Сочи (862)225-72-31
Астрахань (8512)99-46-04	Калуга (4842)92-23-67	Омск (3812)21-46-40	Ставрополь (8652)20-65-13
Барнаул (3852)73-04-60	Кемерово (3842)65-04-62	Орел (4862)44-53-42	Сургут (3462)77-98-35
Белгород (4722)40-23-64	Киров (8332)68-02-04	Оренбург (3532)37-68-04	Тверь (4822)63-31-35
Брянск (4832)59-03-52	Краснодар (861)203-40-90	Пенза (8412)22-31-16	Томск (3822)98-41-53
Владивосток (423)249-28-31	Красноярск (391)204-63-61	Пермь (342)205-81-47	Тула (4872)74-02-29
Волгоград (844)278-03-48	Курск (4712)77-13-04	Ростов-на-Дону (863)308-18-15	Тюмень (3452)66-21-18
Вологда (8172)26-41-59	Липецк (4742)52-20-81	Рязань (4912)46-61-64	Ульяновск (8422)24-23-59
Воронеж (473)204-51-73	Магнитогорск (3519)55-03-13	Самара (846)206-03-16	Уфа (347)229-48-12
Екатеринбург (343)384-55-89	Москва (495)268-04-70	Санкт-Петербург (812)309-46-40	Хабаровск (4212)92-98-04
Иваново (4932)77-34-06	Мурманск (8152)59-64-93	Саратов (845)249-38-78	Челябинск (351)202-03-61
Ижевск (3412)26-03-58	Набережные Челны (8552)20-53-41	Севастополь (8692)22-31-93	Череповец (8202)49-02-64
Иркутск (395)279-98-46	Нижний Новгород (831)429-08-12	Симферополь (3652)67-13-56	Ярославль (4852)69-52-93
Россия (495)268-04-70	Киргизия (996)312-96-26-47	Казахстан (7172)727-132	

Variable Area Flow Meters



GT1600 Model

GT1600 Series

Industrial, Glass Tube Variable Area Flowmeter (Rotameter) for Liquids & Gases

Features

- Configurable to retro-fit GT10xx, GT130x and Full-View
- 360 degrees rotatable viewing angle
- High quality materials for safety, in- and outdoor durability
- 316 stainless steel frame
- Polycarbonate safety shield
- 316/316L dual certified stainless steel process fittings
- Alarms for high- and low flow (optional for all flow ranges, either at time of order, or as add-on in the field)
- Flanged or threaded connections, available horizontal and vertical
- Panel- and wall mount options
- Easy in-situ maintenance: Clean or replace tube and float without removal from the process piping
- Adjust the scale to compensate for process variation
- Optional integral needle valve

Product Specifications

Flow Accuracy	Standard: $\pm 10\%$, $\pm 5\%$, $\pm 2\%$ Full Scale, Class 2.5 acc VDI/VDE Optional: $\pm 1\%$ Full Scale, Class 1.6 acc VDI/VDE
Repeatability	$\leq 0.5\%$ Full Scale
Capacities and Pressure Drops	See Capacities
Scales	Transparent scale. Adjustable Nominal Lengths: 75mm, 127mm and 250mm Choice of direct reading units, millimeter or percentage of maximum flow with factor tag
Ambient Temperature Limits	-4°F to 125°F -20°C to 52°C
Operating Fluid Temperature Limits	33 to 250°F 1°C to 121°C
Mounting options	In-line Panel-mount (see Dimensions) Wall-mount (see Dimensions)

Design compliant to ASME B31.1 & B31.3

Process connections	NPT Threaded		Flanged ANSI 150# RF		
	Horizontal IN/OUT		Horizontal IN/OUT		
	Vertical IN/OUT		Vertical IN/OUT		
	Horizontal IN/ Vertical OUT		Horizontal IN/ Vertical OUT		
	Vertical IN/ Horizontal OUT		Vertical IN/ Horizontal OUT		
Pressure Ratings		Maximum Operating Pressure (PSIG bar) at Fluid Temperature			
	Tube size	Threaded process connections		Flanged process connections	
		psi	bar	psi	bar
	02	300	20.7	240	16.5
	06	300	20.7	240	16.5
	07	300	20.7	240	16.5
	08	250	17.0	240	16.5
	09	200	13.8	200	13.8
	10	175	12.1	175	12.1
Materials of construction	Metering Tube (wetted)	Borosilicate glass			
	Process fittings (wetted)	316/316L (dual certified stainless steel)			
	Float (wetted)	Sizes 2&6: Carboly® or 316/316L (dual certified stainless steel)			
		Sizes 7-10: 316/316L (dual certified stainless steel)			
	Float Stops (wetted)	Teflon®			
	O-rings (wetted)	Viton®, Buna-N, Kalrez®, EPDM			
	Housing	316 stainless steel			
	Window & safety shield	Polycarbonate with UV inhibitor			
Hardware	316 stainless steel				
Alarms	Tube size 02&06	Ring initiator high / low alarm			
	Tube size 07-10	Reed switch high / low alarm			
	Hazardous area approvals	Zone1/Zone2 (ATEX/IECex) – gas/dust. Protection method Ex m (no barrier)			
Div1 (UL) – gas/dust. Protection method I.S.					
Valve	Optional integral needle valve				
Certifications	International Calibration Certificate				
	Material Certification to DIN 3.1				
	Declaration of Compliance 2.1 Oxygen Service				

Product Specifications - Capacities

AA1:L48

			Full Scale - Water				Full Scale - Air				
127-Low Flow	Tube	Float	cc/min	l/h	Pressure Drop inch W.C./kPa	V.I.C. cSt	SLPM	ln/h	Pressure Drop inch W.C./kPa	Alarm Type	
	Size 02	R-2-127-AAAAT	316SS	1.9	0.11	0.7/0.17	1.0	0.11	6.7	0.8/0.19	Ring Initiator
		R-2-127-AAAAT	Carboly	3.7	0.22	1.1/0.27	1.0	0.2	12	1.2/0.3	
		R-2-127-AAT	Carboly	7.5	0.45	1.2/0.29	1.0	0.38	23	1.5/0.37	
		R-2-127-DT	316SS	15	0.93	0.9/0.22	1.0	0.68	40	1.0/0.24	
		R-2-127-DT	Carboly	25	1.5	1.5/0.38	1.0	1	61	1.7/0.42	
		R-2-127-AT	316SS	39	2.3	1.1/0.27	1.0	1.4	86	1.2/0.3	
		R-2-127-AT	Carboly	59	3.5	1.9/0.47	1.0	2	120	2.1/0.52	
		R-2-127-BT	316SS	110	6.8	1.8/0.45	1.0	3.9	230	2.0/0.21	
		R-2-127-BT	Carboly	170	10	3.0/0.75	1.0	5.6	340	3.3/0.83	
	R-2-127-CT	Carboly	270	16	6.1/1.51	1.0	9	540	4.8/1.2		
	Size 06	R-6-127-AT	316SS	410	25	6.1/1.53	1.0	14	850	6.8/1.7	
		R-6-127-AT	Carboly	620	37	10.5/2.61	1.0	20	1200	11.6/2.9	
		R-6-127-BT	316SS	1000	65	30.1/7.5	1.0	35	2100	33.3/8.3	
R-6-127-BT		Carboly	1500	95	57.8/14.4	1.0	49	2900	64.2/16		
250-High Flow	Tube	Float	GPM	l/h	Pressure Drop inch W.C./kPa	V.I.C. cSt	SCFM	m3n/h	Pressure Drop inch W.C./kPa		
Size 07	R-7M-25-1FT	7-XV-11A-A	0.48	100	8/2	1.0	1.8	3.1	10/2.5	Reed Switch	
		7-XS-23-A	0.77	170	16/4.0	1.0	3.3	5.6	17/4.2		
Size 08	R-8M-25-4FT	8-XV-8-A	1.00	240	5/1.5	3.7	4.4	7.5	5/1.3		
		8-XV-14-A	1.40	320	8/2	5.4	5.8	9.9	8/2		
		8-XV-31-A*	2.00	460	16/4	7.0	14	24	17/4.3		
Size 09	R-9M-25-3FT	9-XS-33-A	3.20	730	4/1	2.3	13	22	8/2		
		9-XV-87-A*	3.90	890	14/3.5	17	28	48	16/4		
		9-XS-87-A*	5.10	1100	18/4.5	3.5	36	62	19/4.8		
Size 10	R-10M-25-3FT	10-XV-64-A	6.20	1400	12/3	15	25	43	14/3.5		
		10-XS-64-A	7.80	1700	16/4	3.7	32	54	18/4.5		
		10-XS-138-A*	10.00	2400	30/7.5	5.5	80	130	36/9		
		10-XJ-238-A*	21.00	4800	104/26	1.0	150	270	16/4		
127-High Flow	Size 07	R-7M-127-1FT	7-XV-11A-A	0.41	93	8/2	1.0	1.8	3.1		10/2.5
			7-XS-23-A	0.66	150	16/4.0	1.0	2.7	4.6	17/4.2	
	Size 08	R-8M-127-4FT	8-XV-8-A	0.99	220	5.0/1.25	3.7	4	6.9	6.0/1.5	
			8-XV-14-A	1.3	310	8.0/2	5.4	5.3	9.1	10/2.5	
			8-XV-31-A*	1.7	400	24/6	7.0	11	20	28/7	
	Size 09	R-9M-127-3FT	9-XS-33-A	3.0	690	7.0/1.7	2.3	12	21	8.0/2.0	
			9-XV-87-A*	3.6	830	14/3.5	17	26	44	16/4.0	
			9-XS-87-A*	4.5	1000	17/4.2	3.5	32	55	20/5.0	
	Size 10	R-10M-127-3FT	10-XV-64-A	6	1300	9/2.25	15	24	41	10/2.5	
			10-XS-64-A	7.4	1600	12/3	3.7	30	52	13/3.25	
			10-XS-138-A*	9.8	2200	29/7.25	5.5	68	110	33/8.25	
			10-XJ-238-A*	20	4700	104/26	1.0	140	250	16/4	
	075-High Flow	Size 08	R-8M-75-1	8-XV-8-A	0.82	180	8/2		3.3	5.6	9/2.25
8-RJ-10				1.5	340	9/2.25		6.3	10	11/2.7	
8-RJ-23				2.4	540	13/3.25		9.9	16	15/3.7	
8-RJ-30				3.1	710	19/4.8		13	22	22/5.5	
8-RJ-39				4.7	1000	34/6					
Size 10		R-10M-75-3	10-RJ-80	12	2700	18/4.5					
			10-RJ-180	21	4900	71/17.6					
			10-RJ-37					24	40	18/4.5	
			10-RJ-83					36	62	35/8.7	
			10-RJ-90					55	93	71/17.6	

FRONT VIEW THREADED CONNECTION

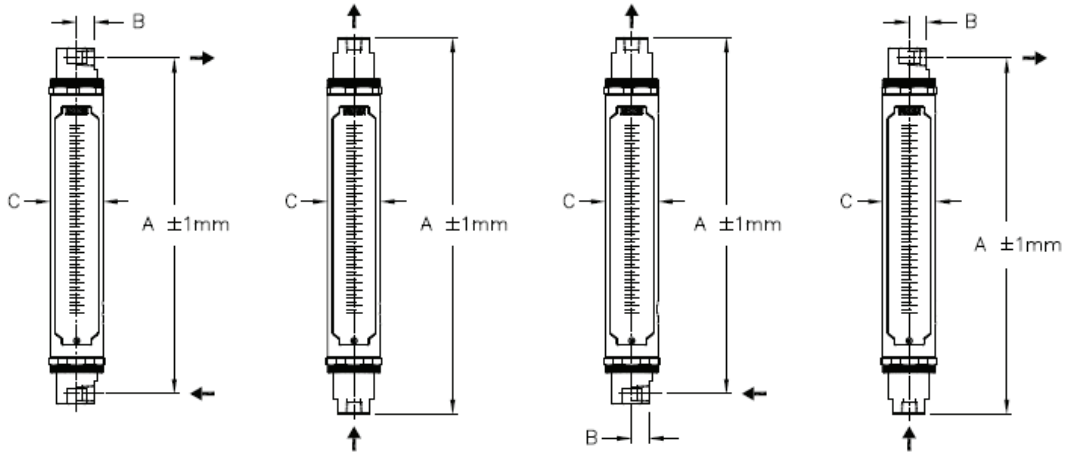

FRONT VIEW FLANGED CONNECTION

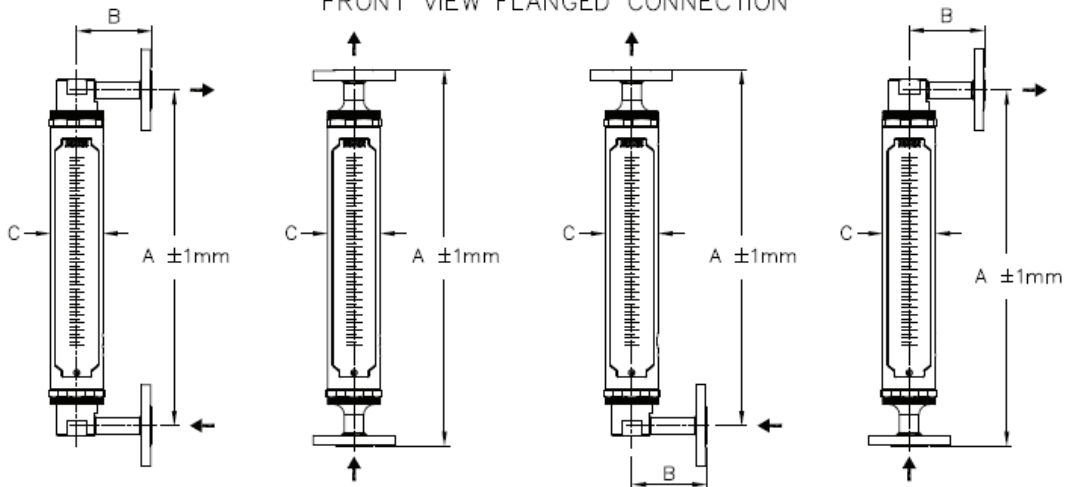

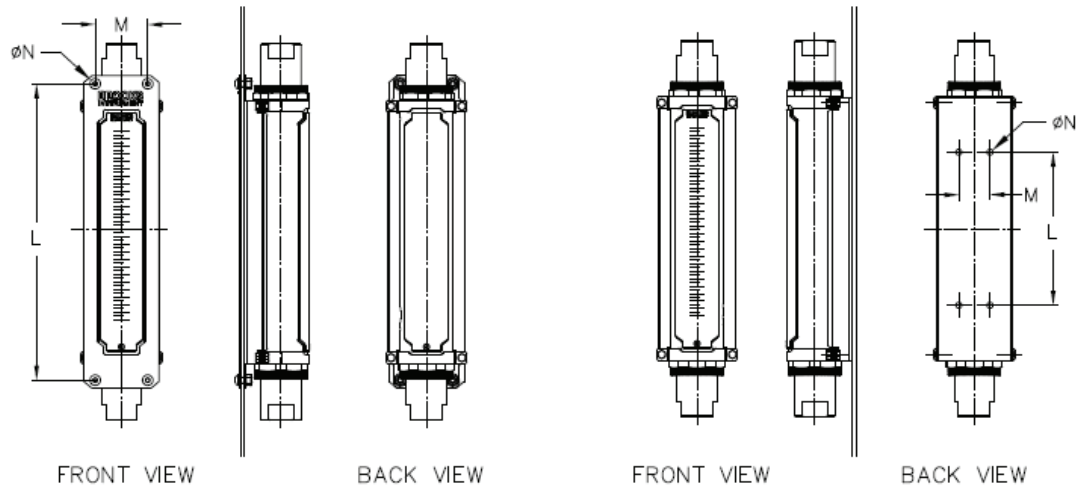

BACK OF PANEL (FLUSH) MOUNTING
(RECTANGULAR PANEL CUT-OUT + 4 MTG. HOLES)

FRONT OF PANEL (WALL) MOUNTING
(4 MOUNTING HOLES)



Product Description - Dimensions

Meter type	Tube size	Process connection	Orientation H(horizontal) V(ertical)	Notes	Retro-fit	Model	Dimension																	
							A		B		C		L		M		N		P		Q			
							inch	mm	inch	mm	inch	mm	inch	mm	inch	mm	inch	mm	inch	mm	inch	mm		
	02 06	NPT-F	H-IN / H-OUT	Standard dimensions ⁽³⁾	GT1000	1020	8.59	218.3	0.59	15.0	1.97	50.0	4.00	101.6	1.00	25.4	0.24	6.0	7.24	184	1.48	37.6		
			V-IN / V-OUT			1024	9.84	250.0	-	-														
			H-IN / V-OUT			1026	9.22	234.1	0.59	15.0														
			V-IN/ H-OUT			1027	9.22	234.1	0.59	15.0														
			H-IN / H-OUT			Retrofit only ⁽⁴⁾	Full-View	1110	8.59	218.3													0.59	15.0
			V-IN / V-OUT					1114	9.63	244.5													-	-
			H-IN / H-OUT	1140	9.11			231.4	0.59	15.0														
			V-IN/ H-OUT	1144	9.11			231.4	0.59	15.0														
			Flanged 150lbs RF	H-IN / H-OUT	Standard dimensions ⁽³⁾	GT1000	1020	8.59	218.3	3.50													75.0	
				V-IN / V-OUT			1024	10.63	270.0	-													-	
				H-IN / V-OUT			1026	9.61	244.1	2.95													75.0	
				V-IN/ H-OUT			1027	9.61	244.1	2.95													75.0	
		H-IN / H-OUT		Retrofit only ⁽⁴⁾			Full-View	1140	8.59	218.3	3.00	101.6												
		V-IN / V-OUT						1144	14.88	377.8	-	-												
			07 08 09 10	NPT-F	H-IN / H-OUT	Standard dimensions ⁽³⁾	GT1000	1020	17.50	444.5	0.91	23.0	2.76	70.0	8.00	203.2	1.63	41.28	0.28	7.0	15.49	393.5	2.74	69.7
					V-IN / V-OUT			1024	19.69	500.0	-	-												
					H-IN / V-OUT			1026	18.59	472.3	0.91	23.0												
					V-IN/ H-OUT			1027	18.59	472.3	0.91	23.0												
H-IN / H-OUT #7/8	Retrofit only ⁽⁴⁾				Full-View			1110	16.50	419.1	0.91	23.0												
H-IN / H-OUT #9/10								1114	17.50	444.5	-	-												
V-IN / V-OUT #7/8						1116	17.00	431.8	-	-														
V-IN / V-OUT #9/10						1117	17.25	438.2	-	-														
H-IN / V-OUT #7/8	Retrofit only ⁽⁴⁾				Full-View	1116	16.75	425.5	0.91	23.0														
H-IN / V-OUT #9/10						1117	17.38	441.3	-	-														
V-IN/ H-OUT #7/8	Retrofit only ⁽⁴⁾				Full-View	1117	16.75	425.5	0.91	23.0														
V-IN/ H-OUT #9/10						1307	17.38	441.3	-	-														
V-IN / V-OUT	Retrofit only ⁽⁴⁾			GT1307	1307	16.94	430.2	-	-															
Flanged 150lbs RF	H-IN / H-OUT #7/8			Standard dimensions ⁽³⁾	GT1000	1020	17.50	444.5	3.94	100.0														
	H-IN / H-OUT #9/10					1024	17.50	444.5	4.72	120.0														
	V-IN / V-OUT					1026	19.69	500.0	-	-														
	H-IN / V-OUT #7/8					1027	18.59	472.3	3.94	100.0														
	H-IN / V-OUT #9/10					1027	18.59	472.3	4.72	120.0														
	V-IN/ H-OUT #7/8	Retrofit only ⁽⁴⁾	Full-View			1140	18.59	472.3	3.94	100.0														
	V-IN/ H-OUT #9/10			1140	17.00	419.1	3.50	88.9																
	H-IN / H-OUT #7/8			1144	17.25	444.5	4.00	101.6																
	H-IN / H-OUT #9/10			1144	22.88	581.0	-	-																
	V-IN / V-OUT #7/8			1146	22.50	571.5	-	-																
	V-IN / V-OUT #9/10			1147	19.69	500.0	3.50	88.9																
	H-IN / V-OUT #7/8	Retrofit only ⁽⁴⁾	Full-View	1146	20.00	508.0	4.00	101.6																
H-IN / V-OUT #9/10	1147			19.69	500.0	3.50	88.9																	
V-IN/ H-OUT #7/8	Retrofit only ⁽⁴⁾	Full-View	1147	20.00	508.0	4.00	101.6																	
V-IN/ H-OUT #9/10			1147	20.00	508.0	4.00	101.6																	

Note (3) - Standard dimension are for new installations







Note (4) - Retro-fit dimensions are for replacement of GT10xx, GT130x and Full-View meters in existing installation. Not for use in new installations.

Product Specifications - Dimensions

Meter type	Tube size	Process connection	Orientation H(horizontal) V(ertical)	Notes	Retro-fit	Model	Dimension										
							A		B		C		L		M		N
							inch	mm	inch	mm	inch	mm	inch	mm	inch	mm	
127-High Flow	07 08 09 10	NPT-F	H-IN / H-OUT	Standard dimensions ⁽³⁾			12.31	312.7	0.91	23.0	2.76	70.0	N/A				
			V-IN / V-OUT				14.50	368.2	-	-							
			H-IN / V-OUT				13.41	340.5	0.91	23.0							
			V-IN / H-OUT				13.95	354.4	0.91	23.0							
		H-IN / H-OUT #7/8	Retrofit only ⁽⁴⁾	Full-View	1110	11.50	292.1	0.91	23.0								
		H-IN / H-OUT #9/10				12.50	317.5	-	-								
		V-IN / V-OUT #7/8				1114	12.00	304.8	-	-							
		V-IN / V-OUT #9/10					12.25	311.2	-	-							
		H-IN / V-OUT #7/8	1116			11.75	298.5	0.91	23.0								
		H-IN / V-OUT #9/10				12.38	314.3	-	-								
		V-IN/ H-OUT #7/8	1117			11.75	298.5	0.91	23.0								
		V-IN/ H-OUT #9/10				12.38	314.3	-	-								
	V-IN / V-OUT	Retrofit only ⁽⁴⁾	GT1306	1306	11.75	298.5	-	-									
	Flanged 150lbs RF		NPT-F	H-IN / H-OUT #7/8	Standard dimensions ⁽³⁾	GT1000		12.31	312.7	3.94							100.0
				H-IN / H-OUT #9/10				4.72	120.0	-							-
				V-IN / V-OUT #7/8				14.50	368.2	-							-
				V-IN / V-OUT #9/10				13.41	340.5	3.94							100.0
			H-IN / V-OUT #7/8				4.72	120.0	-	-							
			H-IN / V-OUT #9/10				3.94	100.0	-	-							
			V-IN/ H-OUT #7/8				13.41	340.5	4.72	120.0							
V-IN/ H-OUT #9/10			4.72				120.0	-	-								
H-IN / H-OUT #7/8			Retrofit only ⁽⁴⁾	Full-View	1140	11.50	292.1	3.50	88.9								
H-IN / H-OUT #9/10						12.50	317.5	4.00	101.6								
V-IN / V-OUT #7/8						1144	17.88	454.0	-	-							
V-IN / V-OUT #9/10							17.50	444.5	-	-							
H-IN / V-OUT #7/8	1146			14.69	373.0	3.50	88.9										
H-IN / V-OUT #9/10				15.00	381.0	4.00	101.6										
V-IN/ H-OUT #7/8	1147			14.69	373.0	3.50	88.9										
V-IN/ H-OUT #9/10				15.00	381.0	4.00	101.6										

Note (3) - Standard dimension are for new installations

Note (4) - Retro-fit dimensions are for replacement of GT10xx, GT130xx and Full-View meters in existing installation. Not for use in new installations.

Declarations	Mark	Meter Options			Standards/Directives/Marking	Status/Certificate	
		Mechanical	Reed Switch	Inductive Alarm			
EU Declaration of Conformity				✓	EMC Directive (2014/30/EU)	Declaration	
			✓	✓	RoHS Directive (2011/65/EU)	Declaration	
			✓	✓	ATEX Directive (2014/34/EU)	Declaration	
		✓			ATEX Directive (2014/34/EU) : Non-Electrical	Declaration	
			✓		EMC Directive (2014/30/EU) The equipment uses a reed switch sensor & is outside the scope of the directive since the inherent nature of the physical characteristics of which is such that: (i) it is incapable of generating or contributing to electromagnetic emissions which exceed a level allowing radio and telecommunication equipment and other equipment to operate as intended; and (ii) it operates without unacceptable degradation in the presence of the electromagnetic disturbance normally consequent upon its intended use.		
		✓	✓	✓	Pressure Equipment Directive (2014/68/EU)	Declaration	
		✓	✓	✓	Canadian Registration Number (CRN)	CRN	
Explosion safety "Constructional safety (c)"	ATEX 	✓			II2G Ex h IIC T6...T4 Gb II2D Ex h IIIC T120°C Db Special conditions for safe use: Refer to IOM	TCF: 203104000-1604	
Explosion safety "encapsulation (m)"	ATEX  IECEX		✓		II 2 G Ex mb IIC T6 Gb II 2 D Ex mb IIIC T85°C Db (Standard Version) II 2 G Ex mb IIC T5 Gb II 2 D Ex mb IIIC T100°C Db (With Junction box Version)	KIWA 18ATEX0013 X	
				✓	Ex mb IIC T6 Gb Ex mb IIIC T85°C Db (Standard Version) Ex mb IIC T5 Gb Ex mb IIIC T100°C Db (With Junction box Version)	IECEX KIWA 18.0008X	
					Standards used for evaluation: EN 60079-0 : 2012+A11: 2013, EN 60079-18 : 2015 IEC 60079-0 : 2011, IEC 60079-18 : 2014		
					Ambient Temperature range: -20 °C to +65 °C (Standard Version) -20 °C to +55 °C (With Junction box Version) Input Power: 30V, 250mA, 3W Special conditions for safe use: Refer to IOM		
Explosion safety "Intrinsic Safety (ia)"			✓		Reed Switch Alarms are classified as "Simple Apparatus" when used in Intrinsically Safe circuits. They comply with the requirements of EN60079-11 clause 5.7 – Simple apparatus. Ambient Temperature ratings: -20° C ≤ Tamb ≤ 65° C Input parameters: Vmax = 30V, Imax = 100mA, Ci = 0µF, Li = 0µH Special conditions for safe use: Refer to IOM		
Explosion safety "Intrinsic Safety (ia)"			✓		IS Class I, II, III, Div 1, Groups A, thru G	UL File E73889 Vol3 Sec 6	
				✓	Inductive Ring Sensor <u>Non-Hazardous Locations</u> Power Supply Current consumption Ambient Temperature	Pepperl + Fuchs Model: RC10-14-N3-Y53478 Pepperl + Fuchs Model: RC15-14-N3-Y53479 Nominal Voltage 8V Operating Voltage 5...25V Active area clear : 3mA (at 8V) Active area obscured: 0.5...0.95mA (at 8V) 0°C to 40°C	
Explosion safety "Intrinsic Safety (ia)"	ATEX  		✓		<u>Hazardous Location</u> ATEX II 2 G Ex ia IIC T6...T1 Gb IP67 Refer to ATEX Certificate for: Input parameters, Max Ambient Temperature, Special conditions for use	Pepperl + Fuchs PTB 99 ATEX 2128 X	
			✓		FM Approvals Class I, Division 1, Group A, B, C, Class II, Division 1, Group E, F, G, Class III, Division 1 Class I, Zone 0, Group IIC T6	Pepperl + Fuchs Control Drawing:116-0165G	

Code Description Code Option Option Description

I-II. Base Model Number	16	Horizontal Inlet and Outlet
III. Body - Flow/Scale Length		Body Flow Scale Length
	1	250-High Flow 250mm
	2	127-High Flow 127mm
	3	075-High Flow 75mm
	4	127-Low Flow 127mm
IV. Connection Orientation	0	Horizontal Inlet - Horizontal Outlet
	4	Vertical Inlet - Vertical Outlet
	6	Horizontal Inlet - Vertical Outlet
	7	Vertical Inlet - Horizontal Outlet
V. Model Revision	A	Initial release of global model code

Code	250 - High Flow							
	Water				Air			
	GPM	l/h	SCFM	m3n/h	Tube	Float		
JC	0.48	100	1.8	3.1	J	R-7M-25-1FT	C	7-XV-11A-A
JF	0.77	170	3.3*	5.6*	J	R-7M-25-1FT	F	7-XS-23-A*
KC	1.00	240	4.4	7.5	K	R-8M-25-4FT	C	8-XV-8-A
KF	1.40	320	5.8	9.9	K	R-8M-25-4FT	F	8-XV-14-A
KJ	2.00	460	14*	24*	K	R-8M-25-4FT	J	8-XV-31-A*
LC	3.20	730	13	22	L	R-9M-25-3FT	C	9-XS-33-A
LF	3.90	890	28*	48*	L	R-9M-25-3FT	F	9-XV-87-A*
LJ	5.10	1100	36*	62*	L	R-9M-25-3FT	J	9-XS-87-A*
MC	6.20	1400	25	43	M	R-10M-25-3FT	C	10-XV-64-A
MF	7.80	1700	32	54	M	R-10M-25-3FT	F	10-XS-64-A
MJ	10.00	2400	80*	130*	M	R-10M-25-3FT	J	10-XS-138-A*
MM	21.00	4800	150*	270*	M	R-10M-25-3FT	M	10-XJ-238-A*

* These codes require a back pressure of 30 psig /2 bar

Code	127 - High Flow							
	Water				Air			
	GPM	l/h	SCFM	m3n/h	Tube	Float		
SC	0.41	93	1.8	3.1	S	R-7M-127-1FT	C	7-XV-11A-A
SF	0.66	150	2.7*	4.6*	S	R-7M-127-1FT	F	7-XS-23-A*
TC	0.99	220	4	6.9	T	R-8M-127-4FT	C	8-XV-8-A
TF	1.3	310	5.3	9.1	T	R-8M-127-4FT	F	8-XV-14-A
TJ	1.7	400	11*	20*	T	R-8M-127-4FT	J	8-XV-31-A*
UC	3	690	12	21	U	R-9M-127-4FT	C	9-XS-33-A
UF	3.6	830	26*	44*	U	R-9M-127-4FT	F	9-XV-87-A*
UJ	4.5	1000	32*	55*	U	R-9M-127-4FT	J	9-XS-87-A*
VC	6	1300	24	41	V	R-10M-127-3FT	C	10-XV-64-A
VF	7.4	1600	30	52	V	R-10M-127-3FT	F	10-XS-64-A
VJ	9.8	2200	68*	110*	V	R-10M-127-3FT	J	10-XS-138-A*
VM	20	4700	140*	250*	V	R-10M-127-3FT	M	10-XJ-238-A*

* These codes require a back pressure of 30 psig/2 bar

Code	075 - High Flow							
	Water				Air			
	GPM	l/h	SCFM	m3n/h	Tube	Float		
PC	0.82	180	3.3	5.6	P	R-8M-75-1	C	8-XV-8-A
PF	1.5	340	6.3	10	P	R-8M-75-1	F	8-RJ-10
PJ	2.4	540	9.9	16	P	R-8M-75-1	J	8-RJ-23
PM	3.1	710	13	22	P	R-8M-75-1	M	8-RJ-30
PQ	4.7	1000	N/A	N/A	P	R-8M-75-1	Q	8-RJ-39
RC	12	2700	N/A	N/A	R	R-10M-75-3	C	10-RJ-80
RF	21	4900	N/A	N/A	R	R-10M-75-3	F	10-RJ-180
RJ	N/A	N/A	24	40	R	R-10M-75-3	J	10-RJ-37
RM	N/A	N/A	36	62	R	R-10M-75-3	M	10-RJ-83
RQ	N/A	N/A	55	93	R	R-10M-75-3	Q	10-RJ-90

Code Description Code Option Option Description

VI-VII. Maximum Flowrate (continued)	127 - Low Flow								
	Code	Water			Air		Tube		Float
		cc/min	l/h	SLPM	In/h				
A3	1.9	0.11	0.11	6.7	A	R-2-127-AAAAT	3	316SS	
A6	3.7	0.22	0.2	12	A	R-2-127-AAAAT	6	CARBOLOY	
B6	7.5	0.45	0.38	23	B	R-2-127-AAT	6	CARBOLOY	
C3	15	0.93	0.68	40	C	R-2-127-DT	3	316SS	
C6	25	1.5	1	61	C	R-2-127-DT	6	CARBOLOY	
D3	39	2.3	1.4	86	D	R-2-127-AT	3	316SS	
D6	59	3.5	2	120	D	R-2-127-AT	6	CARBOLOY	
E3	110	6.8	3.9	230	E	R-2-127-BT	3	316SS	
E6	170	10	5.6	340	E	R-2-127-BT	6	CARBOLOY	
F6	270	16	9	540	F	R-2-127-CT	6	CARBOLOY	
G3	410	25	14	850	G	R-6-127-AT	3	316SS	
G6	620	37	20	1200	G	R-6-127-AT	6	CARBOLOY	
H3	1000	65	35	2100	H	R-6-127-BT	3	316SS	
H6	1500	95	49	2900	H	R-6-127-BT	6	CARBOLOY	

VIII. Fitting Material	A	316 Stainless Steel
	B	316 Stainless Steel w/ CRN

IX. Connection Size	1	1/4" Low Flow
	2	1/2" High Flow
	3	3/4" High Flow
	4	1" High Flow
	5	1" Vertical / 3/4" Horizontal. Size 10 only.

X. - XI. Connection Type	AA	Standard / GT1000 Retrofit	NPT - Female
	AB	Standard / GT1000 Retrofit	ANSI #150 RF Flange
	BA	Retrofit GT130x	NPT - Female
	CA	Retrofit Full-View 11xx	NPT - Female
	CB	Retrofit Full-View 11xx	ANSI 150# RF Flange
	DC	Retrofit GT1000	Rc - Female\

XII. O-Ring Material	1	Viton® fluoroelastomer
	2	Buna
	3	Kalrez®
	4	EPDM

XIII. Scale Inscription	1	MM Scale
	2	Percent Scale
	3	Direct Reading Scale
	4	Dual Scale

XIV. Meter Accuracy	A	±10%
	B	±5% Full Scale
	D	±2% Full Scale
	F	±1% Full Scale
	G	2.5 VDI/VDE
	H	1.6 VDI/VDE

XV. Valve Type/Location	0	None
	1	Valve at Inlet
	2	Valve at Outlet

XVI. Alarm	0	None
	1	1 Switch/Sensor
	2	2 Switches/Sensors

XVII. Approvals	A	None
	B	ATEX - Zone 1 & Zone 2, non-Electrical
	C	UL / FM - Hazardous location
	D	ATEX - Zone 1 & Zone 2, Electrical

Sample Standard Model Code

I-II	III	IV	V	VI-VII	VIII	IX	X-XI	XII	XIII	XIV	XV	XVI	XVII
16	1	4	A	D0	A	2	AA	1	3	D	0	0	A

* These parts and services are not part of the product model code but should be selected during product configuration.

Accessory Parts

CONDULET JUNCTION BOX ASSEMBLY

<i>from 16xxG Model Code, position 16</i>		Part Numbers for Relays
Option Code	Description	
0	None	
1	1 Switch/Sensor	203Z023AAA
2	2 Switches/Sensor	203Z023AAA

RELAY

<i>from 16xxG Model Code, position 16</i>		Part Numbers for Relays		
Alarm		110VAC 1 or 2 relay	220VAC 1 or 2 relay	24VAC 1 or 2 relay
Option Code	Description			
0	None			
1	1 Switch/Sensor	029G008ZZZ	or	029G010ZZZ or 029G012ZZZ
2	2 Switches/Sensor	029G008ZZZ	or	029G010ZZZ or 029G012ZZZ

MOUNTING KITS

<i>from 16xxG Model Code, position 3</i>			Part Numbers for Kits	
Option Code	Flow/Scale Length		Front of panel (wall) mounting	Back of panel (flush) mounting
	Description			
1	250 - High Flow	250mm	778Z019AAA	778Z021AAA
2	127 - High Flow	127mm	778Z018AAA	778Z020AAA
3	075 - High Flow	75mm	NA	NA
4	127 Low Flow	127mm	778Z018AAA	778Z020AAA

Services

- Clean for Oxygen Service 2.1
- Commercial Cleaning
- Declaration of Compliance 2.1
- International Calibration Certificate (ICC)
- Material Certification 3.1
- NACE MR0175 MR0103
- PMI (Positive Material Identification)
- Pressure Test Certificate 2.2

По вопросам продаж и поддержки обращайтесь:

Алматы (7273)495-231	Казань (843)206-01-48	Новокузнецк (3843)20-46-81	Смоленск (4812)29-41-54
Архангельск (8182)63-90-72	Калининград (4012)72-03-81	Новосибирск (383)227-86-73	Сочи (862)225-72-31
Астрахань (8512)99-46-04	Калуга (4842)92-23-67	Омск (3812)21-46-40	Ставрополь (8652)20-65-13
Барнаул (3852)73-04-60	Кемерово (3842)65-04-62	Орел (4862)44-53-42	Сургут (3462)77-98-35
Белгород (4722)40-23-64	Киров (8332)68-02-04	Оренбург (3532)37-68-04	Тверь (4822)63-31-35
Брянск (4832)59-03-52	Краснодар (861)203-40-90	Пенза (8412)22-31-16	Томск (3822)98-41-53
Владивосток (423)249-28-31	Красноярск (391)204-63-61	Пермь (342)205-81-47	Тула (4872)74-02-29
Волгоград (844)278-03-48	Курск (4712)77-13-04	Ростов-на-Дону (863)308-18-15	Тюмень (3452)66-21-18
Вологда (8172)26-41-59	Липецк (4742)52-20-81	Рязань (4912)46-61-64	Ульяновск (8422)24-23-59
Воронеж (473)204-51-73	Магнитогорск (3519)55-03-13	Самара (846)206-03-16	Уфа (347)229-48-12
Екатеринбург (343)384-55-89	Москва (495)268-04-70	Санкт-Петербург (812)309-46-40	Хабаровск (4212)92-98-04
Иваново (4932)77-34-06	Мурманск (8152)59-64-93	Саратов (845)249-38-78	Челябинск (351)202-03-61
Ижевск (3412)26-03-58	Набережные Челны (8552)20-53-41	Севастополь (8692)22-31-93	Череповец (8202)49-02-64
Иркутск (395)279-98-46	Нижний Новгород (831)429-08-12	Симферополь (3652)67-13-56	Ярославль (4852)69-52-93
Россия (495)268-04-70	Киргизия (996)312-96-26-47	Казахстан (7172)727-132	